

## NUFFIELD-LUCAS DYNAMO POLARISATION

The following instructions are for polarising the dynamo on '**positive earth**' tractors.

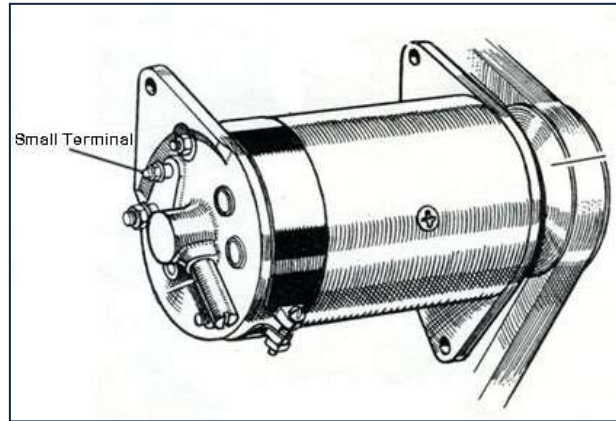

- Fit the dynamo to the tractor but **do not** attach the wires to the dynamo.
- Connect the tractor's battery leads to the tractor.
- Connect one end of a jump lead to the 'negative' (live) terminal on the battery and briefly stroke the other end across the small terminal on the dynamo.
- When you see a small blue spark the dynamo will be polarised to suit your tractor and the field coils are magnetised to suit the polarity.
- Connect the dynamo terminals.

For more Nuffield tractor information and parts contact us.

[J Charnley & Sons Website](#)

[Charnleys Twitter](#)

[Charnleys Facebook](#)